

FERUS 20 IN SQ H.P.LED



TECHNICAL DETAILS

- Housing:** Pressed formed steel / Extruded aluminium
- Rotation:** Vertical 90° / Horizontal 360°
- Control Gear:** Built-in electronic driver
- Watt:** 1W / 1.5W
- IP:** 40
- IK:** 05
- LED replacement with tools

Colors



Lighting Sources



Module 1x H.P.LED - CRI80 - Ripple <3%

- 1W - 350mA - 2700K - 150Lm | 1.5W - 500mA - 2700K - 210Lm
- 1W - 350mA - 3000K - 155Lm | 1.5W - 500mA - 3000K - 215Lm
- 1W - 350mA - 4000K - 170Lm | 1.5W - 500mA - 4000K - 230Lm

Lenses: 10°/24°/34°

3step MacAdam - LM80 test report - Lifetime>50.000h L80B10

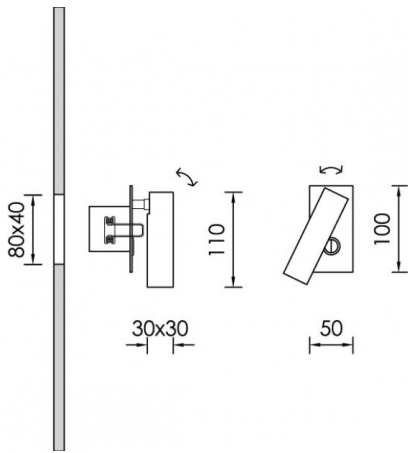

Lighting

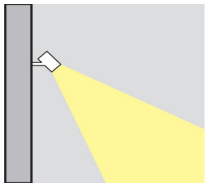

Photometric

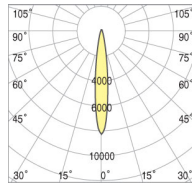

Headoffice - Showroom: 13 Sofokli Venizelou Ave., Likovrisi, P.O. Box 14123, Athens, Greece. Tel: +30 210 28 51 304 Fax: +30 210 28 51 306

Factory - Financial Services: 5 Kefalovrisou Str., Monomati, Aharnai, P.O. Box 13677 Athens, Greece. Tel: +30 210 62 08 230 Fax: +30 210 62 08 262

website: www.bright.gr | **e-mail:** info@bright.gr