

## FORTIS Q PILLAR



## TECHNICAL DETAILS

<b>Housing:</b>	Cast-pressed aluminium / Extruded aluminium
<b>Diffuser:</b>	Safety glass clear / Safety glass sandblast
<b>Rotation:</b>	Vertical 90°
<b>Reflector:</b>	Circular diamond aluminium (15°, 24°, 40°, 60°)
<b>IP:</b>	54
<b>IK:</b>	06
	<ul style="list-style-type: none"> <li>Reflector replacement with tools</li> <li>LED replacement with tools</li> </ul>

## Colors



-132  
Grey matt



-44  
White matt



-119  
Black matt



-502  
Anthracite

## Lighting Sources

**PrevaLED Core AC G2 | CRI80**

8.6W - 3000K - 800Lm - 93Lm/W
8.9W - 2700K - 800Lm - 90Lm/W
18.4W - 4000K - 2000Lm - 109Lm/W
19.6W - 3000K - 2000Lm - 102Lm/W

**3 step MacAdam | Ripple < 3%**  
**LM80 test report | Lifetime>50.000h**

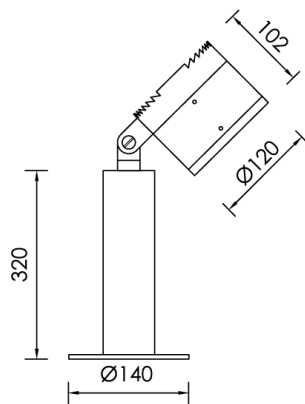

Lighting

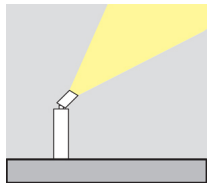

Photometric

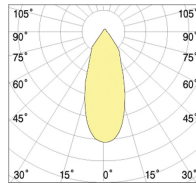

**Headoffice - Showroom:** 13 Sofokli Venizelou Ave., Likovrisi, P.O. Box 14123, Athens, Greece. Tel: +30 210 28 51 304 Fax: +30 210 28 51 306

**Factory - Financial Services:** 5 Kefalovrisou Str., Monomati, Aharai, P.O. Box 13677 Athens, Greece. Tel: +30 210 62 08 230 Fax: +30 210 62 08 262

**website:** [www.bright.gr](http://www.bright.gr) | **e-mail:** [info@bright.gr](mailto:info@bright.gr)